

Driver LCU 150 W 12 V indoor IP20
excite series 12 V – not dimmable (IP20)

Product description

- Constant voltage LED driver
- Universal input voltage range
- Constant output voltage
- Complies with CLASS C from minimum to maximum load range according to EN 61000-3-2
- Nominal lifetime up to 50,000 h (at t_a 40 °C with a failure rate max. 0.2 % per 1,000 h)
- 5 years guarantee (conditions at www.tridonic.com)

Properties

- High efficiency
- Low power loss
- Overtemperature and overload protection
- Short-circuit shutdown feature with automatic restart
- Protection class II, SELV
- Type of protection IP20
- Plastic casing white



IP20 SELV 
RoHS

Driver LCU 150 W 12 V indoor IP20
excite series 12 V – not dimmable (IP20)

Technical data

Rated supply voltage	120 – 240 V
AC voltage range	108 – 264 V
Rated current (at 230 V 50 Hz)	1.75 A
Mains frequency	0 / 50 / 60 Hz
Efficiency	> 88 %
λ (at 230 V 50 Hz)	0.95
Output voltage tolerance	+ 10 %
Output power	150 W
Output power range	20 – 150 W
Output P_{S1}^{LM} (at full load)	≤ 1
Output SVM (at full load)	≤ 0.4
Turn on time (output)	≤ 0.5 s
Turn off time (output)	≤ 1 s
Hold on time at power failure (Output)	10 ms
Ambient temperature t_a	-25 ... +50 °C
Ambient temperature t_a (at lifetime 50,000 h)	-25 ... +40 °C
Storage temperature t_s	-30 ... +85 °C
Lifetime	up to 50,000 h
Guarantee (conditions at www.tridonic.com)	5 years
Dimensions LxWxH	270 x 63 x 40.5 mm
Hole spacing D	246 mm

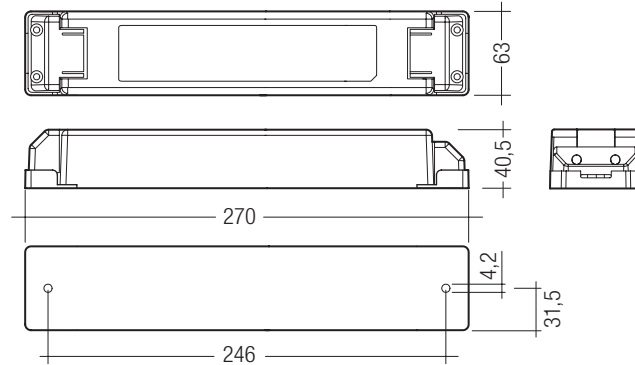

Ordering data

Type	Article number	Packaging carton	Packaging pallet	Weight per pc.
LCU 150/12 E020	24166332	20 pc(s).	640 pc(s).	0.8 kg

Specific technical data

Type	Max. casing temperature t_c	Output voltage	Max. input power	Output current range
LCU 150/12 E020	80 °C	12 V	176 W	1,250 – 12,500 mA

Standards

EN 55015
 EN 61000-3-2
 EN 61000-3-3
 EN 61347-1
 EN 61347-2-13
 EN 61547
 EN 62384
 Acc. to 50172: 24 V LED driver suitable for central battery systems

Overload protection

If the maximum load is exceeded by a defined internal limit, occurs an automatic shutdown of the LED driver.
 Automatic restart if the output current is below the limit.

No-load operation

The LED driver is not damaged in the no-load operation. The max. output voltage (see page1) can be obtained during no-load operation.

Over temperature protection

Automatic shutdown of the LED driver if the temperature limit is exceeded.
 Automatic restart if the temperature falls below the limit.

Glow wire test according to EN 60695-2-11

850 °C passed.

Maximum loading of automatic circuit breakers in relation to inrush current

Automatic circuit breaker type	C10	C13	C16	C20	B10	B13	B16	B20	Inrush current	
Installation Ø	1.5 mm ²	1.5 mm ²	1.5 mm ²	2.5 mm ²	1.5 mm ²	1.5 mm ²	1.5 mm ²	2.5 mm ²	I_{max}	time
LCU 150/0012 E020	4	4	7	8	2	2	3	4	94.1A	0.325 ms

These are max. values calculated out of inrush current! Please consider not to exceed the maximum rated continuous current of the circuit breaker.
 Calculation uses typical values from ABB series S200 as a reference.
 Actual values may differ due to used circuit breaker types and installation environment.

Harmonic distortion in the mains supply (at 230 V / 50 Hz and full load) in %

Type	THD	3	5	7	9	11
LCU 150/0012 E020	14	13	2	2	2	1

LCU 150/0012 E020 – Efficiency versus load

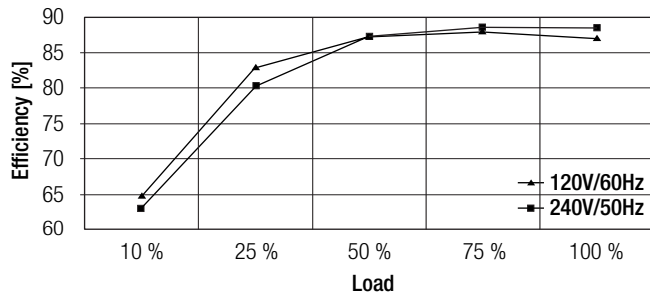

LCU 150/0012 E020 – PF value versus load

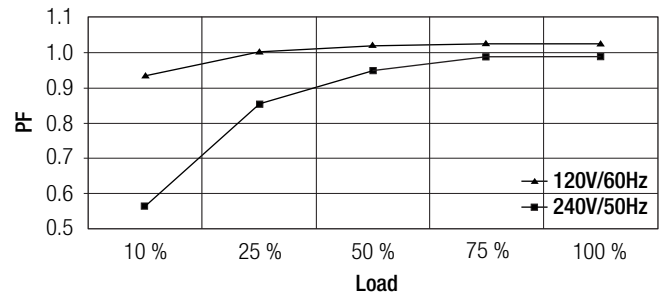

Wiring diagram

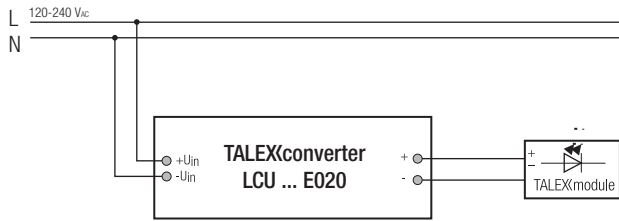

Installation instructions

The switching of LEDs on secondary side is not permitted.
A proper functioning of the LCU in combination with third party dimming devices (e.g. PWM) cannot be guaranteed.

Please note that LCU 150 complies with protection class II so special measures are needed if it is to be installed in protection class I applications / luminaires.

Please note the requirements set out in the document LED_Betriebsgeraete_installationshinweis.pdf (<http://www.tridonic.com/com/de/technische-doku.asp>).

To avoid the damage of the Driver, the wiring must be protected against short circuits to earth (sharp edged metal parts, metal cable clips, louver, etc.).

Insulation and electric strength testing of luminaires

Electronic devices can be damaged by high voltage. This has to be considered during the routine testing of the luminaires in production.

According to IEC 60598-1 Annex Q (informative only!) or ENEC 303-Annex A, each luminaire should be submitted to an insulation test with 500 V_{DC} for 1 second. This test voltage should be connected between the interconnected phase and neutral terminals and the earth terminal. The insulation resistance must be at least 2 MΩ.

As an alternative, IEC 60598-1 Annex Q describes a test of the electrical strength with 1500 V_{AC} (or 1.414 x 1500 V_{DC}). To avoid damage to the electronic devices this test must not be conducted.

Additional information

Additional technical information at www.tridonic.com → Technical Data

Lifetime declarations are informative and represent no warranty claim.
No warranty if device was opened.

Wiring type and cross section

The wiring can be in stranded wires with ferrules or solid. For perfect function of the screw terminals the strip length should be 7.5–8.5 mm for the terminal.

Max. torque at the clamping screw: 0.5 Nm

The maximum secondary cable length at the terminals is 2 m.
The LED wiring should be kept as short as possible to ensure good EMC.
To comply with the EMC regulations run the secondary wires (LED module) in parallel.

Input / Output terminal

PRI and SEC:

